

Name: \_\_\_\_\_

# Electricity part 5 AQA Triple Physics

Date: \_\_\_\_\_

---

Time: **58 minutes**

Marks: **56 marks**

Comments:

---

1.

A student set up the electrical circuit shown in the figure below.

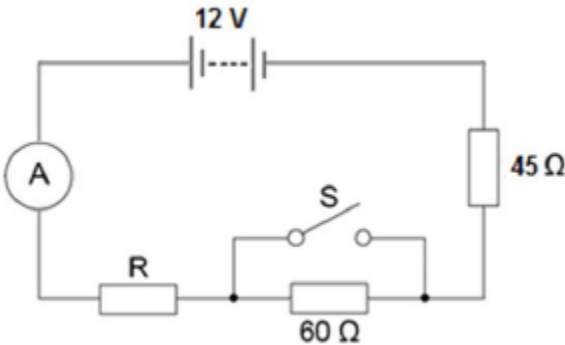

(a) The ammeter displays a reading of 0.10 A.

Calculate the potential difference across the 45 Ω resistor.

---

---

Potential difference = \_\_\_\_\_ V

(2)

(b) Calculate the resistance of the resistor labelled R.

---

---

---

Resistance = \_\_\_\_\_ Ω

(3)

(c) State what happens to the total resistance of the circuit and the current through the circuit when switch S is closed.

---

---

---

---

(2)

(Total 7 marks)

2.

A student investigated how current varies with potential difference for two different lamps.

Her results are shown in the figure below.

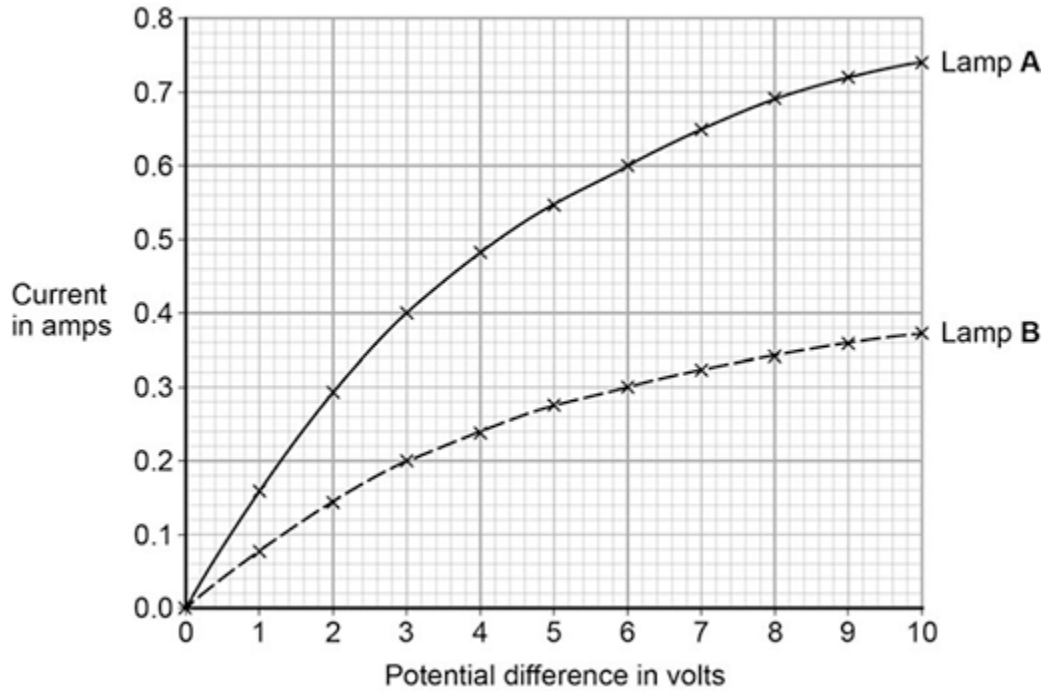

- (a) Complete the circuit diagram for the circuit that the student could have used to obtain the results shown in the figure above.



(3)

- (b) Which lamp will be brighter at any potential difference?

Explain your answer.

Use the figure above to aid your explanation

---

---

---

---

(2)

(c) Lamp **B** has the higher resistance at any potential difference.

Explain how the figure above shows this.

---

---

---

---

**(2)**

(d) Both lamps behave like ohmic conductors through a range of values of potential difference.

Use the figure above to determine the range for these lamps.

Explain your answer.

---

---

---

---

---

---

**(3)**

**(Total 10 marks)**

3.

Figure 1 shows a Van de Graaff generator that is used to investigate static electricity.

Before it is switched on, the metal dome has no net charge.

After it is switched on, the metal dome becomes positively charged.

Figure 1



© Michael Priest

(a) Explain how an uncharged object may become positively charged.

---

---

---

---

---

---

---

(3)

- (b) **Figure 2** shows a plan view of the positively charged metal dome of a Van de Graaff generator.

Draw the electric field pattern around the metal dome when it is isolated from its surroundings.

Use arrows to show the direction of the electric field.

**Figure 2**



**(2)**

(c) Another positively charged object is placed in the electric field.

Look at **Figure 3**.

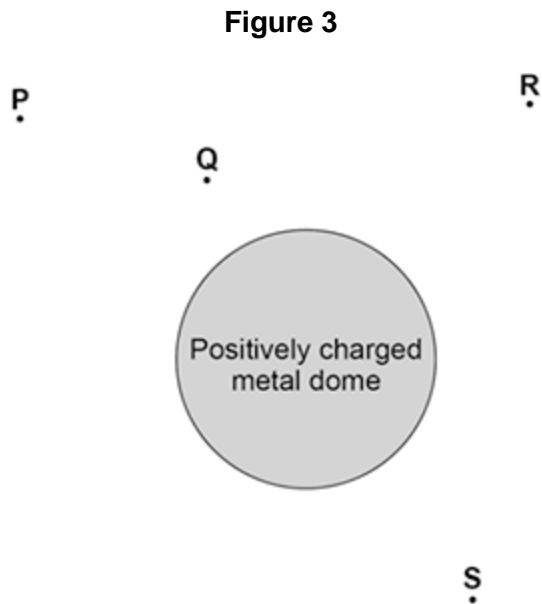

In which position would the object experience the greatest force?

Tick **one** box.

<b>P</b>	<input type="checkbox"/>
<b>Q</b>	<input type="checkbox"/>
<b>R</b>	<input type="checkbox"/>
<b>S</b>	<input type="checkbox"/>

**(1)**  
**(Total 6 marks)**

4.

An electrician is replacing an old electric shower with a new one.

The inside of the old shower is shown in the figure below.



© Michael Priest

- (a) The electrician should **not** change the shower unless he switches off the mains electricity supply.

Explain why.

---

---

---

---

(2)

- (b) The new shower has a power output of 10 690 W when it is connected to the 230 V mains electricity supply.

The equation which links current, potential difference and power is:

$$\text{current} = \frac{\text{power}}{\text{potential difference}}$$

Calculate the current passing through the new shower.

Give your answer to two significant figures.

---

---

---

Current = \_\_\_\_\_ A

**(4)**

- (c) The new shower has a higher power rating than the old shower.

How does the power of the new shower affect the cost of using the shower?

Give a reason for your answer.

---

---

---

---

**(2)**

**(Total 8 marks)**

5.

- (a) A washing machine is connected to the mains electricity supply using a cable and three-pin plug.

Figure 1 shows a three-pin plug.

Figure 1

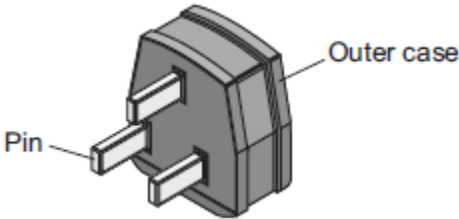

Name the materials used in the structure of a plug. Give the reason why each material is used.

Pin \_\_\_\_\_

\_\_\_\_\_

Outer case \_\_\_\_\_

\_\_\_\_\_

(1)

- (b) The three-pin plug contains a fuse. The fuse is connected to one of the wires inside the cable.

(i) Which **one** of the wires inside the cable is the fuse connected to?

\_\_\_\_\_

(1)

(ii) The fuse is a thin wire inside a closed glass tube. The wire acts as a resistor.

What effect does a current through a wire have on the wire?

\_\_\_\_\_

(1)

- (iii) The power of the washing machine varies between 0.7 kW and 2 kW depending on which part of the wash cycle is operating.

Calculate the maximum current drawn from the mains electricity supply by the washing machine.

The mains electricity supply is at a potential difference of 230 V.

---

---

---

Current = \_\_\_\_\_ A

(2)

- (c) **Figure 2** shows how the mains electricity cable is connected to the washing machine.

The earth wire is connected to the metal case of the washing machine.

**Figure 2**

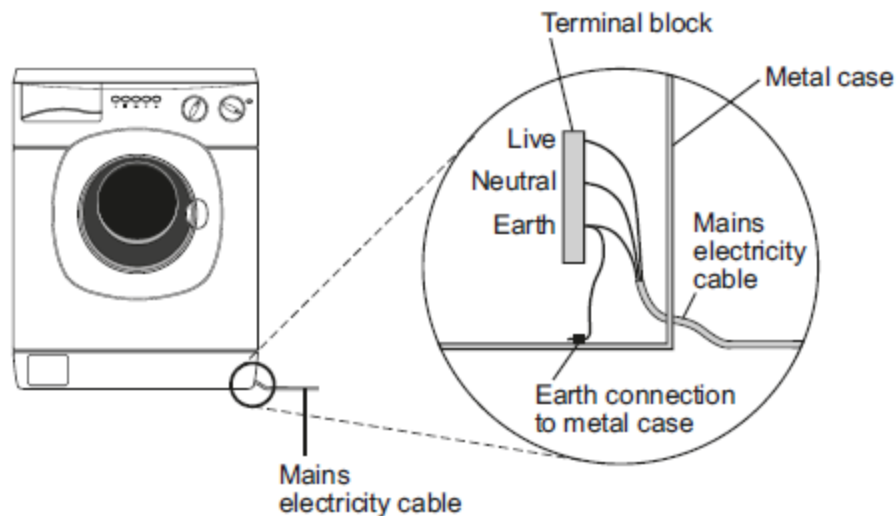

If a fault makes the metal case live, the earth wire and fuse inside the plug prevent the mains cable from overheating and causing a fire.

Explain how.

---

---

---

---

(2)

- (d) New research has shown that many people underestimate the hazards of using mains electricity.

It is important that people do understand the hazards of using mains electricity.

Suggest why.

---



---



---

(1)

(Total 9 marks)

6.

- (a) **Figure 1** shows the inside of a battery pack designed to hold three identical 1.5 V cells.

**Figure 1**

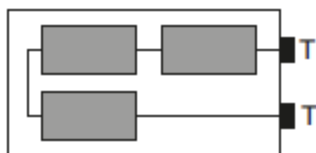

Which **one** of the arrangements shown in **Figure 2** would give a 4.5 V output across the battery pack terminals **T**?

**Figure 2**

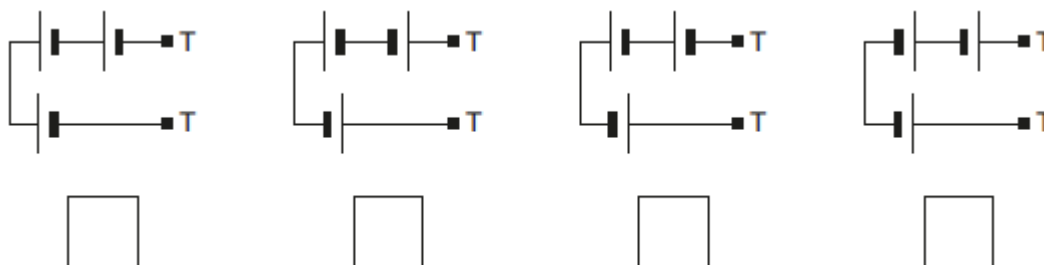

(1)

- (b) **Figure 3** shows a variable resistor and a fixed value resistor connected in series in a circuit.

**Figure 3**

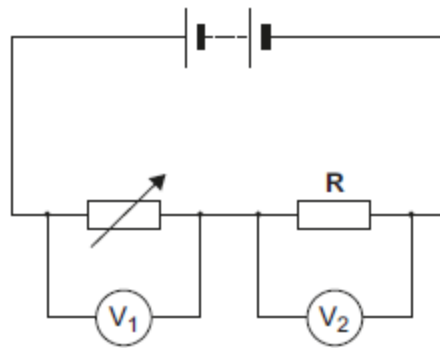

Complete **Figure 3** to show how an ammeter would be connected to measure the current through the circuit.

Use the correct circuit symbol for an ammeter.

(1)

- (c) The variable resistor can be adjusted to have any value from 200 ohms to 600 ohms.

**Figure 4** shows how the reading on voltmeter  $V_1$  and the reading on voltmeter  $V_2$  change as the resistance of the variable resistor changes.

**Figure 4**

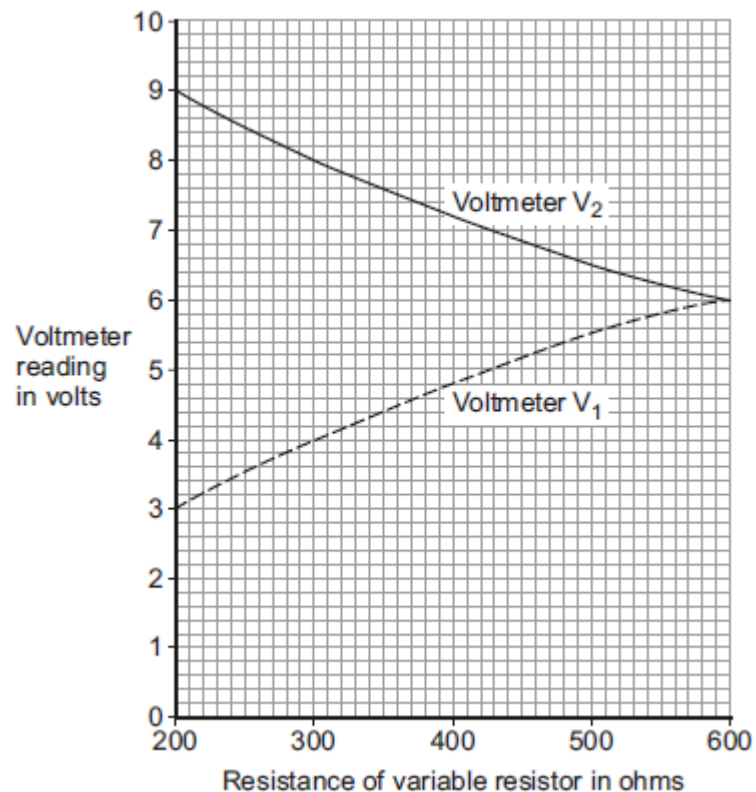

(i) How could the potential difference of the battery be calculated from **Figure 4**?

Tick (✓) **one** box.

$9 + 3 = 12 \text{ V}$

$9 - 3 = 6 \text{ V}$

$9 \div 3 = 3 \text{ V}$

Give the reason for your answer.

---

---

(2)

(ii) Use **Figure 4** to determine the resistance of the fixed resistor, **R**.

Resistance of R = \_\_\_\_\_  $\Omega$

Give the reason for your answer.

---

---

(2)

(iii) Calculate the current through the circuit when the resistance of the variable resistor equals  $200 \Omega$ .

---

---

---

Current = \_\_\_\_\_ A

(3)

(Total 9 marks)

7.

Figure 1 shows the apparatus used to investigate how the current through a thermistor depends on the temperature of the thermistor.

Figure 1

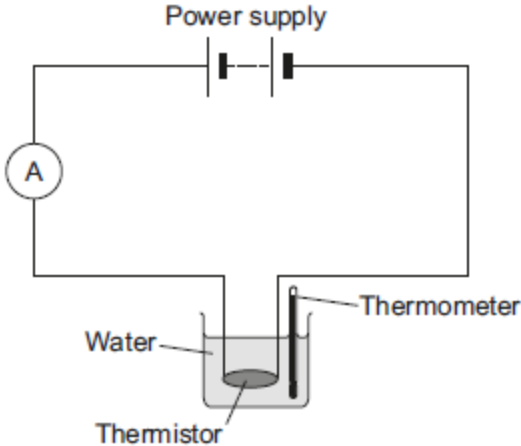

(a) Which **one** of the following is the correct circuit symbol for a thermistor?

Tick (✓) **one** box.

<input type="checkbox"/>	<input type="checkbox"/>	<input type="checkbox"/>

(1)

(b) To get a range of results, hot water at 60 °C was poured into the beaker. The temperature of the water and current through the thermistor were then recorded as the water cooled.

The results of the investigation are shown in Figure 2.

Figure 2

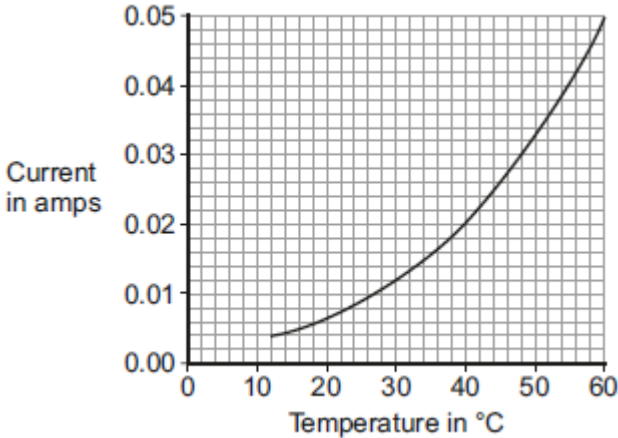

- (i) Suggest **one** way the investigation could have been changed to give a wider range of temperatures.

---

---

(1)

- (ii) Describe how the current through the thermistor depends on the temperature of the thermistor.

---

---

(1)

- (iii) Use **Figure 2** to determine the current through the thermistor at 40 °C.

Current at 40 °C = \_\_\_\_\_ A

(1)

- (iv) At 40 °C the thermistor has a resistance of 250 Ω.

Use your answer to part **(iii)** and the resistance of the thermistor to calculate the potential difference across the thermistor.

---

---

---

---

Potential difference = \_\_\_\_\_ V

(2)

- (v) The potential difference across the thermistor stays the same all through the investigation.

What conclusion can be made from the results in **Figure 2** about the resistance of the thermistor as the temperature of the thermistor **decreases**?

Tick (✓) **one** box.

the resistance increases

the resistance does not change

the resistance decreases

(1)  
(Total 7 marks)

## Mark schemes

1.

(a)  $V = 0.10 \times 45$

4.5 (V)

(b)  $R = 12 / 0.10$

total resistance = 120 ( $\Omega$ )

$R = 120 - 105 = 15$  ( $\Omega$ )

(c) (total) resistance decreases

(so) current increases

2.

(a)

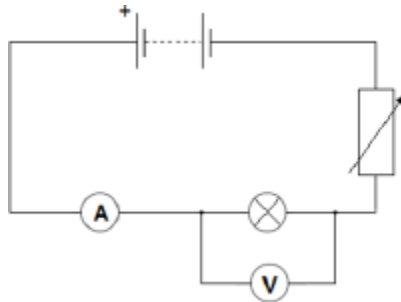

*battery in series with bulb and ammeter*

*voltmeter in parallel with bulb*

*variable resistor*

**or**

*variable power pack*

**or**

*potentiometer*

(b) A is brighter because it has a higher current (than lamp B at any p.d.)

(therefore A has a) higher power output (than bulb B)

*accept higher energy output per second*

(c) lower current (than lamp A) for the same potential difference

*accept answer in terms of  $R = V / I$*

*allow reference to a comparison of the gradients*

1

this is true for all values (of p.d. on the graph)

1

(d) 0 – 2 Volts

*allow a range from 0 V up to any value between 1 and 2 V.*

1

(for an ohmic conductor) current is directly proportional to potential difference

*allow lines (of best fit) are straight and pass through the origin*

1

(so) resistance is constant

1

**[10]**

**3.**

(a) negatively charged

1

electrons are transferred

1

from the (neutral) object

1

(b) minimum of four lines drawn perpendicular to surface of sphere

*judge by eye*

1

minimum of one arrow shown pointing away from sphere

*do **not** accept any arrow pointing inwards.*

1

(c) Q

1

**[6]**

**4.**

(a) he may receive an electric shock

**or**

he may be electrocuted

1

if he touches the live wire

1

(b)  $10\,690 = I \times 230$

1

$I = 10\,690 / 230$

1

46.478(260) (A)

1

46

1

*allow 46 (A) with no working shown for 4 marks*

(c) cost is higher

1

more energy is used (per second)

1

**[8]**

**5.**

(a) pin

made from brass because it is (hard and) a (good electrical) conductor

*accept copper for brass*

*metal is insufficient*

*heat conductor on its own negates*

1

outer case

plastic/rubber because it is a (good electrical) insulator

*heat insulator on its own negates*

1

(b) (i) live

1

(ii) makes it hot/warm

*melts is insufficient*

1

(iii) 8.7

*accept an answer that rounds to 8.7*

*allow 1 mark for correct substitution ie  $2000 = 230 \times I$*

*an answer of 0.0087 or 0.009 or 3.0(4) or 5.65 or 5.7 gains 1 mark*

2

(c) a (large) current goes from the live wire to the earth wire

*accept metal case for live wire*

*accept a current goes from live to earth*

*do not accept electricity for current*

1

(which causes) the fuse to (overheat and) melt

*accept blow for melt*

*break is insufficient*

*do not accept snap / blow up for melt*

1

- (d) reduce chance of an electric shock  
*accept to reduce the risk of an accident*  
*accept prevent electric shock*  
*accept prevent electrocution*  
*accept prevent or reduce the risk of an (electrical) fire*  
*accept an electric shock can kill you*  
*accept it can kill you*  
*accept so you can use it safely*

1

[9]

6.

- (a) 3<sup>rd</sup> box from the left ticked

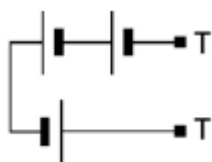

1

- (b) correct symbol drawn in series with other components  
*symbol must have upper case A*

1

- (c) (i)  $9 + 3 = 12V$   
*reason only scores if this mark scored*

1

pd of battery is shared between the variable resistor and fixed resistor  
*accept  $V_1 + V_2 = pd$  of the battery*  
*accept p.d. is shared in a series circuit*  
*accept voltage for p.d.*

1

- (ii) 600  
*reason only scores if this mark scored*

1

p.d. of supply shared equally when resistors have the same value  
**or**  
 ratio of the p.d. is the same as the ratio of the resistance

1

- (iii) 0.015  
**or**  
 their (c)(i)  $\div$  (their (c)(ii) + 200) correctly calculated  
*allow 2 marks for correct substitution ie  $12 = I \times 800$*   
**or**  
*their (c)(i) =  $I \times$  (their (c)(ii) + 200)*  
*allow 1 mark for total resistance = 800 ( $\Omega$ ) or their (c)(ii) + 200*  
**or**  
*allow 1 mark for a substitution of  $12 = I \times 200$*   
**or**  
*their (c)(i) =  $I \times 200$*   
**or**  
*alternative method using the graph*  
 $V = 3 \text{ V (1)}$   
 $3 = I \times 200 \text{ (1)}$

3

[9]

- 7.** (a) last box ticked



1

- (b) (i) use hotter water (than 60 °C)  
*accept use boiling water*  
*accept use water at any stated temperature above 60 °C*

**or**

add ice cubes

*accept add water at any stated temperature below 12 °C*  
*use different temperatures is insufficient*

1

- (ii) the current increases as the temperature increases

1

- (iii) 0.02 (A)

1

- (iv) 5 (V)

**or**

their (b)(iii)  $\times$  250 correctly calculated

*allow 1 mark for correct substitution ie  $V = 0.02 \times 250$*

**or**

$V =$  their (b)(iii)  $\times$  250

2

(v) the resistance increases

1  
[7]