

Name: _____

Electricity part 2 AQA Triple Physics

Date: _____

Time: **81 minutes**

Marks: **76 marks**

Comments:

1.

Figure 1 shows some overhead power cables in the National Grid.

Figure 1



(a) Explain the advantage of transmitting electricity at a very high potential difference.

(3)

(b) It is dangerous for a person to fly a kite near an overhead power cable.

Figure 2 shows a person flying a kite.

Figure 2



The person could receive a fatal electric shock if the kite was very close to, but not touching the power cable.

Explain why.

(3)

A scientist investigated how the potential difference needed for air to conduct charge varies with the distance between a cable and earth.

Figure 3 shows the results.

Figure 3

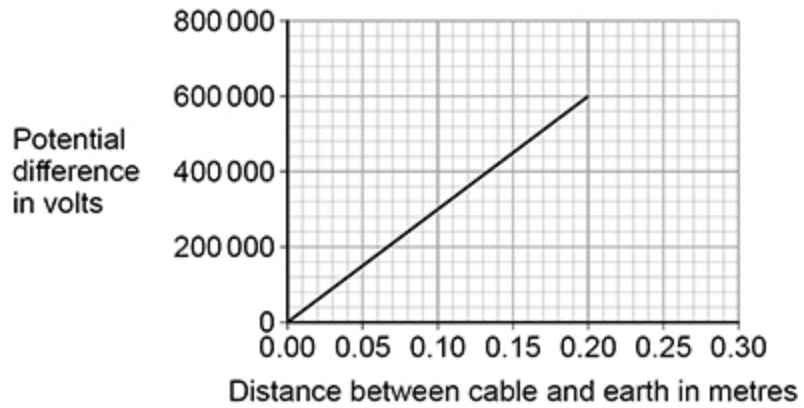

- (c) The data in **Figure 3** gives the relationship between potential difference and distance when the air is dry.

When the humidity of air increases the air becomes a better conductor of electricity.

Draw a line on **Figure 3** to show how the potential difference changes with distance if the humidity of the air increases.

(2)

(d) **Figure 4** shows a cross-section through a power cable.

Figure 4

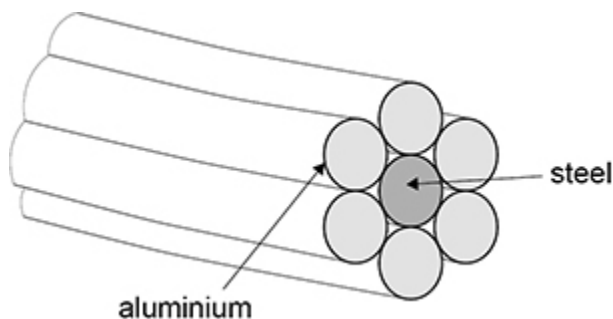

A 1 metre length of a single aluminium wire is a better conductor than a 1 metre length of the steel wire.

The individual wires behave as if they are resistors connected in parallel.

Explain why the current in the steel wire is different to the current in a single aluminium wire.

(2)

(Total 10 marks)

2.

The diagram below shows how the National Grid connects power stations to consumers.

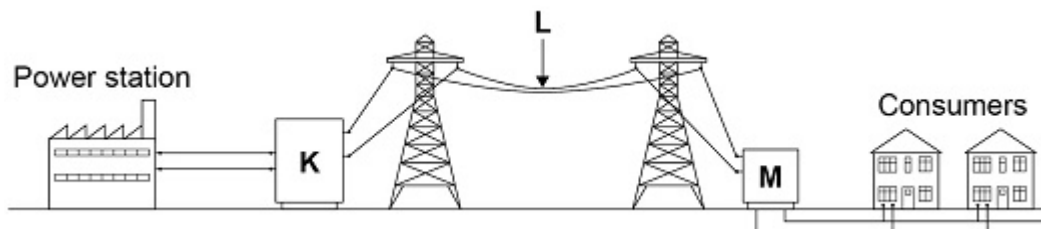

(a) Name the parts of the National Grid labelled K, L and M.

K = _____

L = _____

M = _____

(3)

Figure 1 shows how the percentage of electricity generated by gas-fired power stations changed in the UK over 5 years.

Figure 1

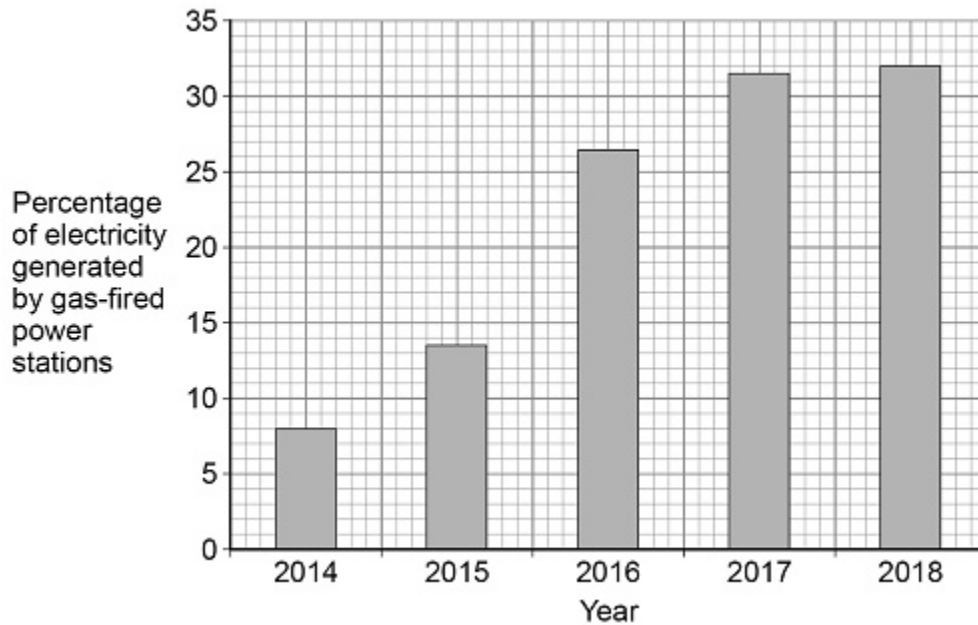

(b) Calculate how many times greater the percentage of electricity generated by gas-fired power stations was in 2018 than in 2014.

Number of times greater = _____

(2)

(c) Explain **one** environmental effect of generating electricity using a gas-fired power station.

(2)

- (d) The UK government wants more electricity to be generated using renewable energy resources.

What is a renewable energy resource?

Tick (✓) **one** box.

An energy resource that can be burned

An energy resource that can be recycled

An energy resource that can be replenished quickly

An energy resource that can be reused

(1)

(e) An offshore wind farm is a group of wind turbines that are placed out at sea.

Figure 2 shows the power output of an offshore wind farm compared with a wind farm on land for a 24-hour period.

Figure 2

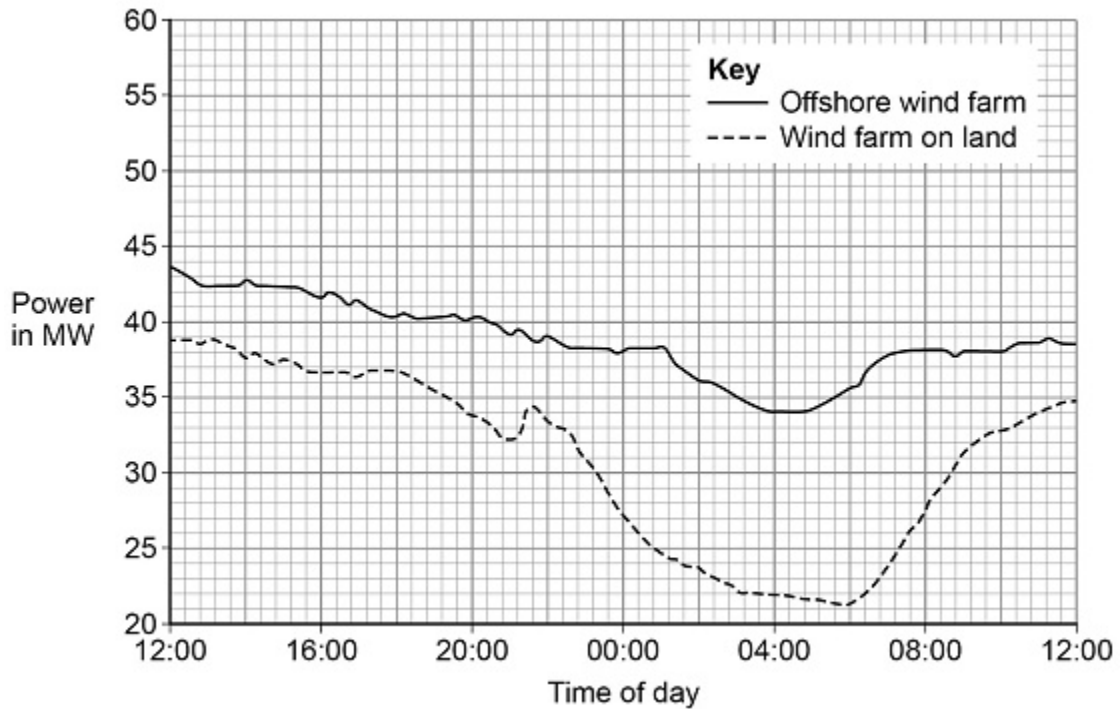

Give **two** advantages of the offshore wind farm compared with the wind farm on land.

Use information from **Figure 2**.

- 1 _____

- 2 _____

(2)
(Total 10 marks)

3. The diagram shows part of a lighting circuit in a house.

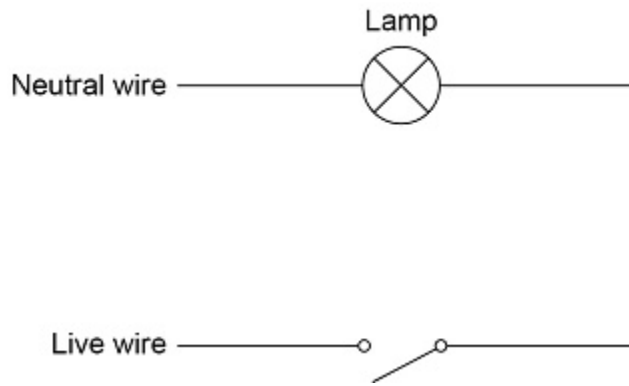

(a) What is the frequency of the ac mains electricity supply in the UK?

Tick (✓) **one** box.

20 Hz 50 Hz 60 Hz 100 Hz

(1)

(b) The mains electricity supply has an alternating potential difference.

Which diagram shows an alternating potential difference?

Tick (✓) **one** box.

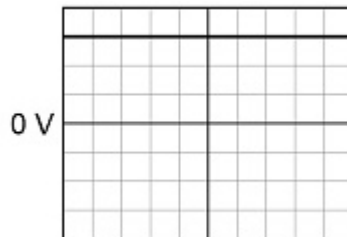
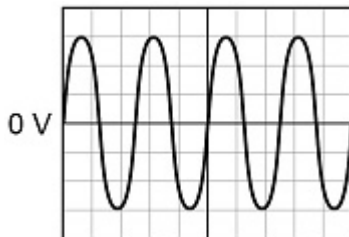

(1)

(c) The potential difference across the lamp is 230 V.

The current in the lamp is 0.020 A.

Calculate the power output of the lamp.

Use the equation:

$$\text{power} = \text{potential difference} \times \text{current}$$

$$\text{Power} = \text{_____} \text{ W}$$

(2)

(d) The potential difference across the lamp is 230 V.

Calculate the energy transferred by the lamp when 180 C of charge flows through the lamp.

Use the equation:

$$\text{energy transferred} = \text{charge flow} \times \text{potential difference}$$

$$\text{Energy transferred} = \text{_____} \text{ J}$$

(2)

(e) An electrician needs to replace the light switch in the diagram above.

Describe the possible hazard and the risk to the electrician of changing the light switch.

Hazard

Risk

(2)

(Total 8 marks)

4.

A student investigated how the total resistance of identical resistors connected in series varied with the number of resistors.

The student used an ohmmeter to measure the total resistance of the resistors.

The diagram below shows the student's circuit with 3 resistors.

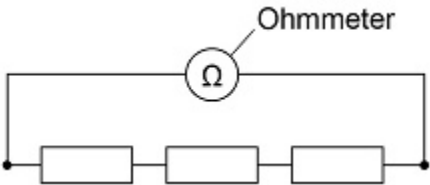

The student repeated each reading of resistance three times.

The table below shows the student's results for 3 resistors in series.

Number of resistors	Total resistance in Ω			
	Reading 1	Reading 2	Reading 3	Mean
3	35.9	36.0	36.1	36.0

(a) Calculate the mean resistance of 1 resistor.

Resistance = _____ Ω

(2)

(b) What was the resolution of the ohmmeter the student used?

Tick (✓) **one** box.

0.1 Ω 0.2 Ω 1.1 Ω 36.0 Ω

(1)

(c) How do the results show that the student's measurements were precise?

Tick (✓) **one** box.

The measurements are accurate.

The measurements are grouped closely together.

The measurements are reproducible.

(1)

The graph below shows the results.

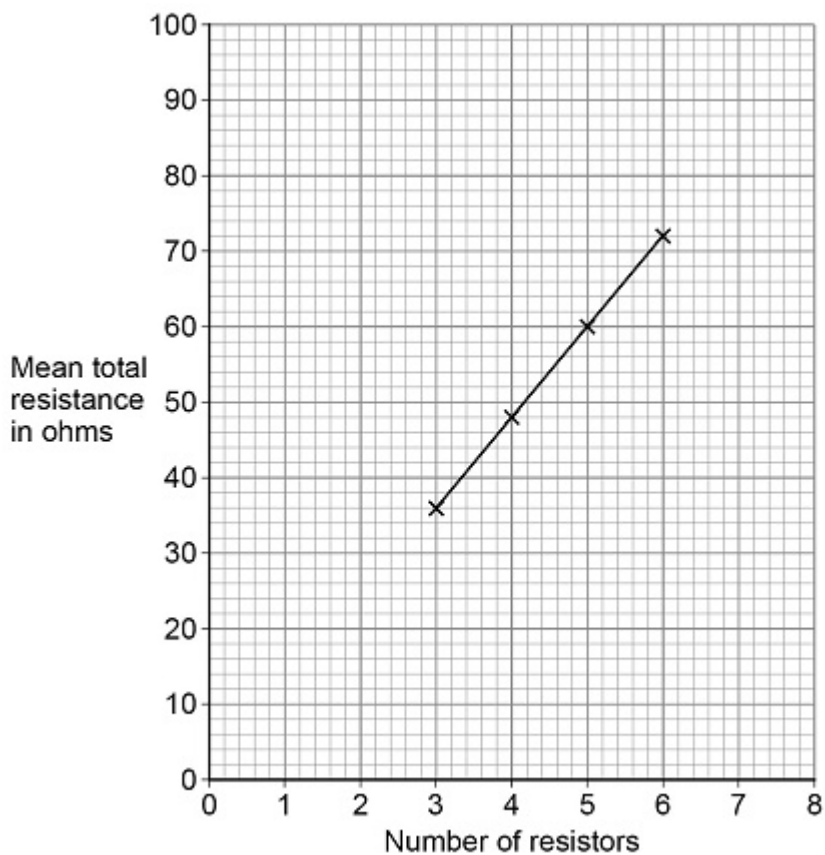

- (d) How do the results show that the total resistance is directly proportional to the number of resistors?

Tick (✓) **one** box.

The results give a line with a positive gradient.

The results give a straight line that would go through the origin.

The results show a linear relationship.

(1)

- (e) Predict the mean total resistance of 7 resistors.

Use the graph above.

Mean total resistance of 7 resistors = _____ Ω

(1)

- (f) Some resistors are connected in series with a battery.

When more resistors are added in series, the total resistance increases.

Complete the sentences.

Choose answers from the box.

Each answer may be used once, more than once or not at all.

decreases

increases

remains the same

When the number of resistors increases, the potential difference across each resistor _____.

When the number of resistors increases, the current in the circuit

_____.

(2)

(Total 8 marks)

5.

A student heated water in an electric kettle.

- (a) Water has a high specific heat capacity.

Complete the sentence.

Choose answers from the box.

°C	J	kg	s	W
-----------	----------	-----------	----------	----------

The specific heat capacity of a substance is the energy needed to raise the temperature of 1 _____ of the substance by 1 _____.

(2)

- (b) The kettle circuit contains a thermistor which is used to switch the kettle off when the water reaches 100 °C.

What is the correct symbol for a thermistor?

Tick (✓) **one** box.

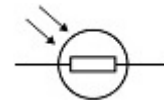
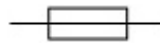
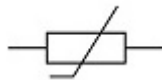

(1)

(c) The resistance of the heating element in the kettle is 15 Ω.

The current in the heating element is 12 A.

Calculate the power of the heating element.

Use the equation:

$$\text{power} = (\text{current})^2 \times \text{resistance}$$

Power = _____ W

(2)

The student investigated how quickly the kettle could increase the temperature of 0.50 kg of water.

The graph below shows the results of the investigation.

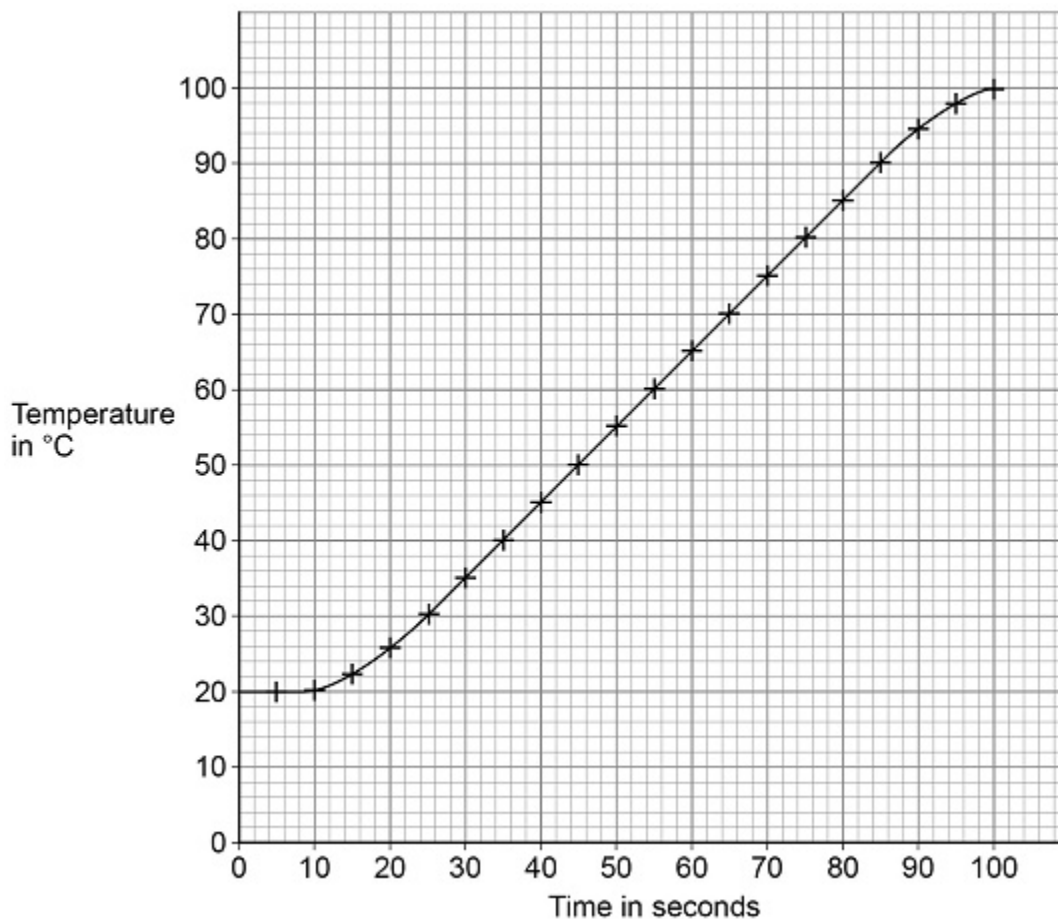

(f) The mass of water in the kettle was 0.50 kg.

The temperature of the water increased from 20 °C to 100 °C.

specific heat capacity of water = 4200 J/kg/°C

Calculate the energy transferred to the water.

Use the Physics Equations Sheet.

Energy = _____ J

(3)

(g) The water in the kettle boiled for a short time before the kettle switched off.

During this time 5.0 g of water changed to steam.

specific latent heat of vaporisation of water = 2 260 000 J/kg

Calculate the energy transferred to change the water to steam.

Use the Physics Equations Sheet.

Energy = _____ J

(3)

(Total 18 marks)

6. A student investigated how the current in a filament lamp varied with the potential difference across the filament lamp.

The diagram below shows part of the circuit used.

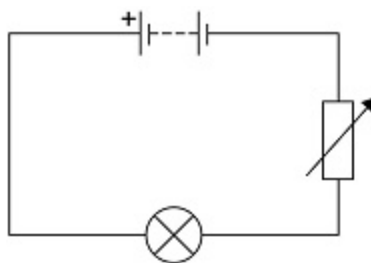

(a) Complete above diagram by adding an ammeter and a voltmeter.

Use the correct circuit symbols.

(3)

The graph below shows some of the results.

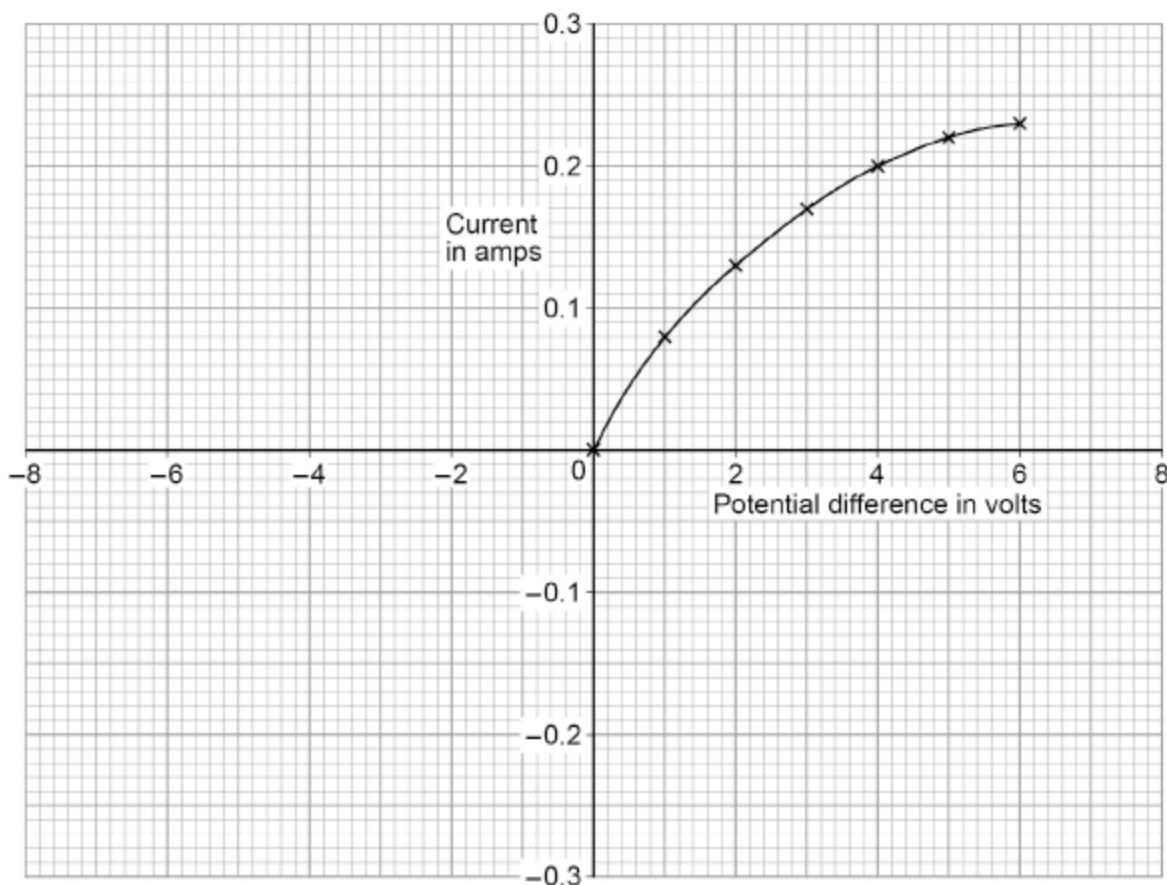

(b) The student reversed the connections to the power supply and obtained negative values for the current and potential difference.

Draw a line on the graph to show the relationship between the negative values of current and potential difference.

(2)

(c) Write down the equation which links current (I), potential difference (V) and resistance (R).

(1)

- (d) Determine the resistance of the filament lamp when the potential difference across it is 1.0 V.

Use data from the graph above.

Resistance = _____ Ω

(4)

- (e) A second student did the same investigation. The ammeter used had a zero error.

What is meant by a zero error?

(1)

(Total 11 marks)

7.

The photograph below shows an LED torch.



(a) The torch contains one LED, one switch and three cells.

Which diagram shows the correct circuit for the torch?

Tick (✓) **one** box.

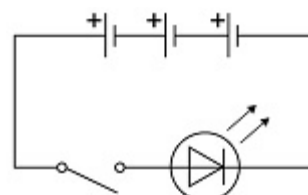
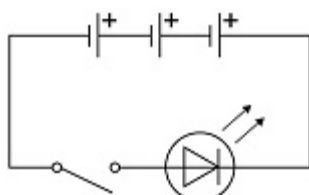
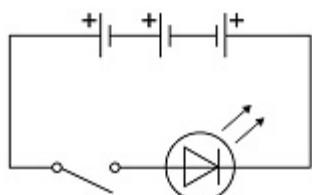

(1)

(b) Write down the equation which links charge flow (Q), current (I) and time (t).

(1)

(c) The torch worked for 14 400 seconds before the cells needed replacing.

The current in the LED was 50 mA.

Calculate the total charge flow through the cells.

Total charge flow = _____ C

(3)

(d) When replaced, the cells were put into the torch the wrong way around.

Explain why the torch did not work.

(2)

(e) Write down the equation which links efficiency, total power input and useful power output.

(1)

(f) The total power input to the LED was 0.24 W.

The efficiency of the LED was 0.75

Calculate the useful power output of the LED.

Useful power output = _____ W

(3)

(Total 11 marks)

Mark schemes

- 1.** (a) (very high p.d. means) very low currents 1
- which means less (thermal) energy is transferred to surroundings
allow less power loss in cables 1
- which increases the efficiency of power transmission 1
- (b) electric field strength is very high 1
- causing the air to become ionised
allow the air breaks down
allow the air becomes a conductor
allow the air conducts charge 1
- (the kite / string) conducts charge to the person / earth
ignore answers referring to the kite touching the power cables 1
- (c) straight line passing through the origin 1
- line drawn below existing line for all values 1
- (d) the potential difference across the wires/cable is the same 1
- (but) the resistance of the steel wire is greater (and so less current in the steel) 1
- [10]**
- 2.** (a) K = step-up transformer 1
- L = transmission cables
allow power cables
ignore wires 1
- M = step-down transformer
allow 1 mark if K and M are labelled transformer but step-up and step-down labels are incorrect or not present 1

(b) 8 (%) and 32 (%)

both required

1

Number of times = 4

1

(c) (burning gas) releases carbon dioxide

1

which causes global warming

allow greenhouse effect or climate change

1

(d) An energy resource that can be replenished quickly.

1

(e) higher power output

allow more electricity generated

1

lower variation in power output

1

[10]

3.

(a) 50 Hz

1

(b)

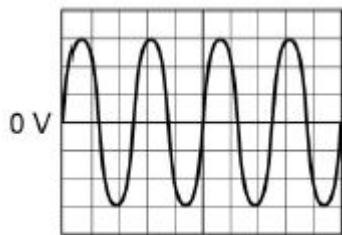

1

(c) $P = 0.020 \times 230$

1

$P = 4.6 \text{ (W)}$

1

(d) $E = 180 \times 230$

1

$E = 41\,400 \text{ (J)}$

1

- (e) Hazard:
live wire
or
high potential difference
ignore current in his body

1

- Risk:
electric shock
or
electrocution

allow (electrical) burn
allow death (by electric shock)
allow 1 mark for hazard and risk in incorrect order

1

[8]

4.

(a) $R = \frac{36.0}{3}$

1

$R = 12.0 (\Omega)$

1

(b) 0.1Ω

1

(c) The measurements are grouped closely together

1

(d) The results give a straight line that would go through the origin.

1

(e) $84 (\Omega)$

allow an answer between 83 and 85 (Ω) inclusive

1

(f) decreases

1

decreases

1

[8]

5.

(a) kg

allow kilogram

1

$^{\circ}\text{C}$

allow degrees Celsius

1

(b)

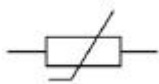

1

(c) $P = 12^2 \times 15$

1

$$P = 2160 \text{ (W)}$$

1

(d) The heating element in the kettle takes time to heat up

1

(e) **Level 3:** The method would lead to the production of a valid outcome. All key steps are identified and logically sequenced.

5–6

Level 2: The method would not necessarily lead to a valid outcome. Most steps are identified, but the method is not fully logically sequenced 3–4

3–4

Level 1: The method would not lead to a valid outcome. Some relevant steps are identified, but links are not made clear.

1–2

No relevant content

0

Indicative content:

- measure the mass of water using a balance
- **or**
- measure the volume of water using a measuring cylinder
- measure the initial temperature of the water
- pour the water into the kettle
- put temperature probe in the water
- **or**
- put a thermometer in the water
- switch kettle on
- record temperature
- measure time with a stopclock
- use an interval of 5 seconds

(f) $\Delta\theta = 80 \text{ (}^\circ\text{C)}$

1

$$E = 0.50 \times 4200 \times 80$$

allow $E = 0.50 \times 4200 \times \text{their value of } \Delta\theta$

1

$$E = 168\,000 \text{ (J)}$$

allow an answer consistent with their value of $\Delta\theta$

1

(g) $m = 0.005 \text{ (kg)}$

1

$E = 0.005 \times 2\,260\,000$

this mark may score if m is not/incorrectly converted

1

$E = 11\,300 \text{ (J)}$

allow an answer consistent with their value of m

1

[18]

6.

(a) ammeter and voltmeter symbols correct

1

voltmeter in parallel with lamp

1

ammeter in series with lamp

1

(b) smooth curved line of correct shape

do not accept a line that becomes horizontal

1

passing through - 4.0 V, - 0.2 A

or

- 6.0 V, - 0.23 A

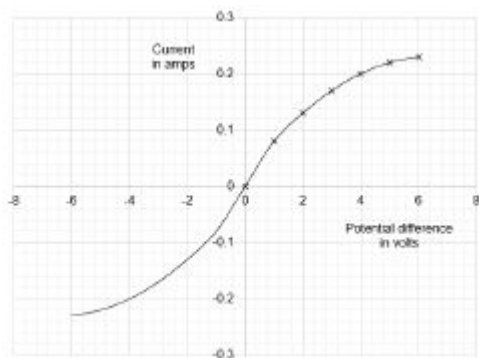

2nd mark conditional on scoring 1st mark

1

(c) potential difference = current \times resistance

or

$V = IR$

1

(d) $I = 0.08 \text{ (A)}$

1

$$1.0 = 0.08 \times R$$

allow $1.0 = \text{their } I \times R$ provided their I has been obtained from the graph

1

$$R = \frac{1.0}{0.08}$$

allow $R = \frac{1.0}{\text{their } I}$

1

$$R = 12.5 \text{ (}\Omega\text{)}$$

allow an answer consistent with their I

1

(e) ammeter displays a reading when not connected (to a circuit)

1

[11]

7.

(a)

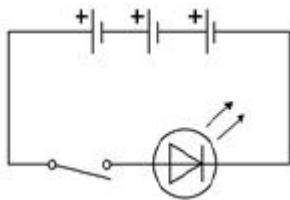

1

(b) charge flow = current \times time
or

$$Q = It$$

1

(c) $I = 0.050 \text{ (A)}$

1

$$Q = 0.050 \times 14\,400$$

allow a correct substitution using an incorrectly/not converted value of I

1

$$Q = 720 \text{ (C)}$$

allow a correct calculation using an incorrectly/not converted value of I

1

- (d) there is no current in a diode (in the reverse direction)
or
charge will not flow through a diode (in the reverse direction)
allow diode will not conduct (electric charge)
do not accept the circuit is not complete

1

(because) a diode has a (very) high resistance (in the reverse direction)

1

(e) Efficiency = $\frac{\text{Useful power output}}{\text{Total power input}}$

1

(f) $0.75 = \frac{\text{Useful power output}}{0.24}$

1

Useful power output = 0.75×0.24

1

Useful power output = 0.18 (W)

1

[11]