

# Electricity 5

Name: \_\_\_\_\_

Class: \_\_\_\_\_

Date: \_\_\_\_\_

---

Time: **76 minutes**

Marks: **70 marks**

Comments:

---

1.

A student investigated how the potential difference across a filament lamp affects the current in the lamp.

**Figure 1** shows the circuit the student used.

**Figure 1**

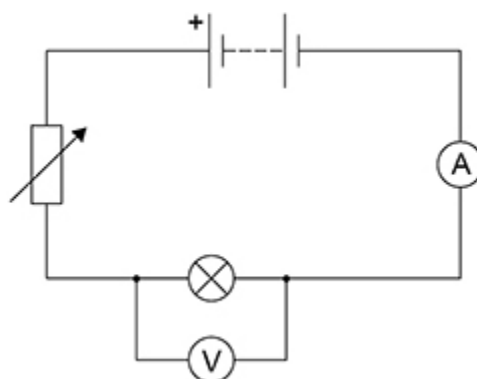

(a) **Figure 2** shows a circuit symbol.

**Figure 2**



What component does the symbol represent?

Tick (✓) **one** box.

Ammeter

Battery

Lamp

Variable resistor

(1)

(b) Which component from **Figure 1** did the student use to adjust the potential difference across the lamp?

---

(1)

(c) When the voltmeter was **not** connected to the circuit it gave a reading of 0.4 volts.

How can the student correct all the readings taken from the voltmeter?

Tick (✓) **one** box.

Add 0.4 volts to each reading

Divide each reading by 0.4 volts

Multiply each reading by 0.4 volts

Subtract 0.4 volts from each reading

(1)

(d) The student recorded three values of current for each potential difference.

The table below shows the results for 2.5 volts.

Potential difference in volts	Current in amps		
	1	2	3
2.5	0.54	0.58	0.53

Calculate the mean current in the lamp.

---

---

---

---

Mean current = \_\_\_\_\_ A

(2)

- (e) Calculate the power of the lamp when the potential difference across the lamp was 4.8 V

The current in the lamp was 0.75 A

Use the equation:

$$\text{power} = \text{potential difference} \times \text{current}$$

---

---

---

---

$$\text{Power} = \text{_____} \text{ W}$$

(2)

- (f) Calculate the resistance of the lamp when the potential difference across the lamp was 4.8 V

The current in the lamp was 0.75 A

Use the equation:

$$\text{resistance} = \frac{\text{potential difference}}{\text{current}}$$

---

---

---

---

$$\text{Resistance} = \text{_____} \Omega$$

(2)

- (g) Complete the sentence.

Choose answers from the box.

Each answer may be used once, more than once or not at all.

<b>decrease</b>	<b>increase</b>	<b>stay the same</b>
-----------------	-----------------	----------------------

Increasing the current in a filament lamp makes the temperature

of the lamp \_\_\_\_\_ and the

resistance of the lamp \_\_\_\_\_.

(2)

(h) Which graph shows the relationship between potential difference and current for a filament lamp?

Tick (✓) **one** box.

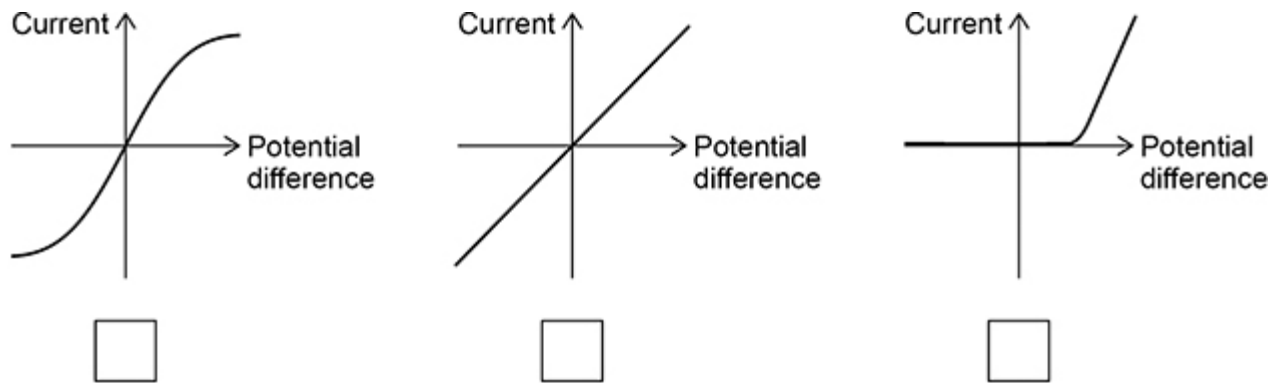

(1)  
(Total 12 marks)

**2.**

**Figure 1** shows how the National Grid transfers energy from a power station to some street lamps.

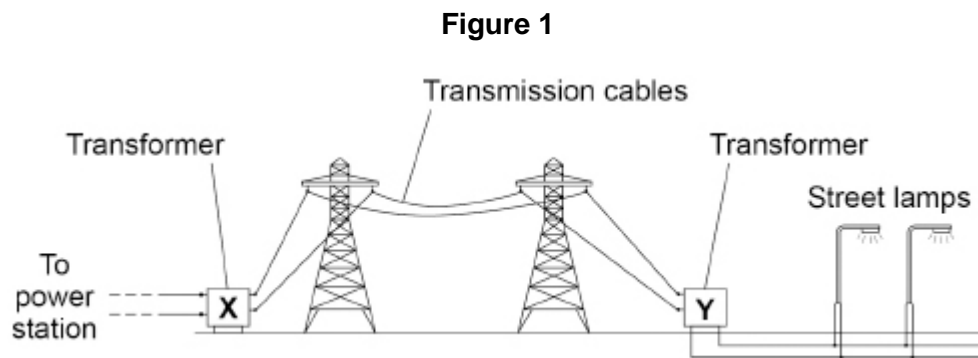

(a) Explain how transformer **X** increases the efficiency of the National Grid.

---



---



---



---



---



---

(3)

(b) The potential difference across the primary coil in transformer **Y** is 400 000 V.

The potential difference across the secondary coil is 11 000 V.

The current in the primary coil is 660 A.

Calculate the current in the secondary coil of transformer **Y**.

Use the Physics Equations Sheet.

---

---

---

---

---

Current in the secondary coil = \_\_\_\_\_ A

**(3)**

(c) Why is the current in each street lamp less than the current in the secondary coil in transformer **Y**?

Tick (✓) **one** box.

Current is used up in the cables between **Y** and each street lamp.

Some of the current is dissipated to the surroundings.

The cables between **Y** and the street lamps have electrical resistance.

The street lamps are connected in parallel.

**(1)**

(d) **Figure 2** shows the top of a street lamp.

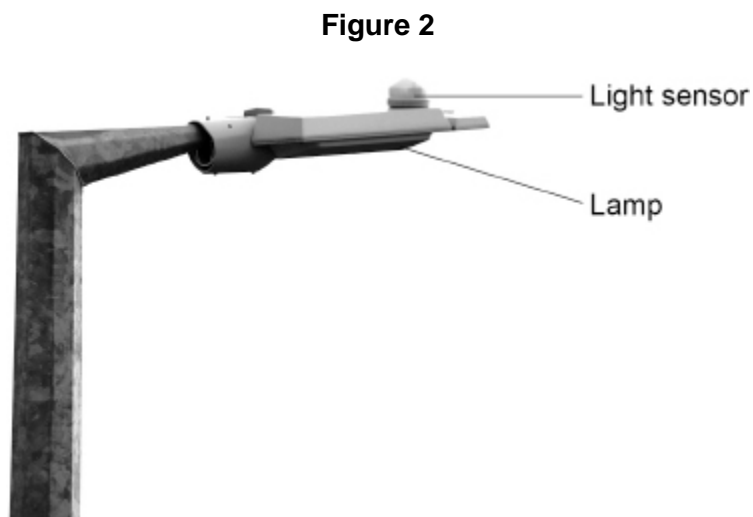

The light sensor detects if it is day or night.

**Figure 3** shows part of the circuit in the light sensor.

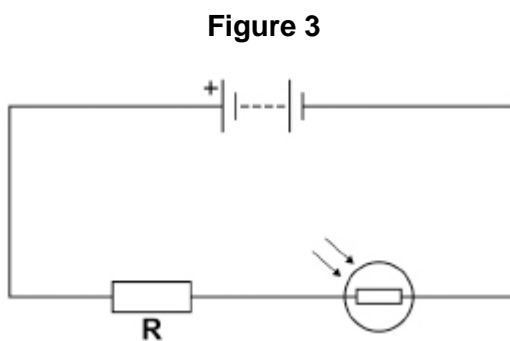

Explain what happens to the potential difference across resistor **R** as the light intensity decreases.

---

---

---

---

---

---

---

(3)

(e) When the current in resistor **R** is 20 mA, the power transferred by resistor **R** is 6.0 W.

Calculate the resistance of resistor **R**.

Use the Physics Equations Sheet.

---

---

---

---

---

---

---

---

Resistance = \_\_\_\_\_  $\Omega$

(4)

(Total 14 marks)

**3.**

A filament lamp breaks if the electric current in the filament becomes too big.

(a) What is the correct symbol for a filament lamp?

Tick (✓) **one** box.

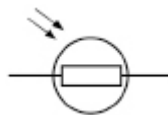
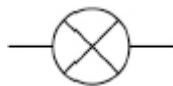
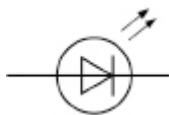

(1)

(b) What is meant by an electric current?

Tick (✓) **one** box.

The energy carried by each unit of charge

The flow of electrical charge

The number of electrons in a circuit

The speed at which charge moves

(1)

A manufacturer investigated the maximum current value of some filament lamps.

(c) The figure below shows the symbols for an ammeter, a battery and a variable resistor.



Ammeter



Battery

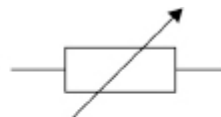

Variable resistor

The manufacturer connected an ammeter, battery, filament lamp and variable resistor in series.

Draw a circuit diagram to show the manufacturer's circuit.

Include the symbol for a filament lamp from part (a)

(1)

(d) How could the manufacturer increase the current in the filament lamp?

Tick (✓) **one** box.

Add an extra ammeter to the circuit.

Decrease the resistance of the variable resistor.

Use a battery with a smaller potential difference.

(1)

- (e) When the potential difference across a filament lamp was 0.75 V, the current in the filament lamp was 0.16 A.

Calculate the power of the filament lamp.

Use the equation:

$$\text{power} = \text{potential difference} \times \text{current}$$

---

---

---

$$\text{Power} = \text{_____} \text{ W}$$

(2)

- (f) Write down the equation which links charge flow ( $Q$ ), current ( $I$ ) and time ( $t$ ).

---

(1)

- (g) The manufacturer increased the current in the filament lamp to 200 mA.

Calculate the charge flow through the filament lamp in 15 s.

---

---

---

---

---

$$\text{Charge flow} = \text{_____} \text{ C}$$

(3)

- (h) The manufacturer increased the current in the filament lamp from 200 mA.

The filament in the lamp broke when the current reached 320 mA.

How many times greater than 200 mA was the current at which the filament broke?

---

---

$$\text{_____} \text{ times greater}$$

(1)

(i) The manufacturer tested lots of filament lamps.

The current at which the filament lamps broke was  $320 \pm 60$  mA.

What is the range of currents at which the filament lamps broke?

Tick (✓) **one** box.

60 mA to 320 mA

260 mA to 320 mA

320 mA to 380 mA

260 mA to 380 mA

(1)

(Total 12 marks)

4.

Figure 1 shows a mobile phone with its battery removed.

Figure 1



A student measured the potential difference across the battery and then put the battery into the phone.

(a) What is the equation linking current ( $I$ ), potential difference ( $V$ ) and resistance ( $R$ )?

Tick (✓) **one** box.

$I = VR$

$R = IV$

$V = IR$

$V = I_2 R$

(1)

(b) The current in the electronic circuit in the mobile phone was 0.12 A.

The potential difference across the battery was 3.9 V.

Calculate the resistance of the electronic circuit in the mobile phone.

---

---

---

---

---

---

---

Resistance = \_\_\_\_\_  $\Omega$

(3)

(c) Write down the equation which links energy ( $E$ ), power ( $P$ ) and time ( $t$ ).

---

(1)

- (d) The battery was fully charged when it was put into the mobile phone.  
 The battery discharged when the mobile phone was switched on.  
 The average power output of the battery as it discharged was 0.46 watts.  
 The time taken to fully discharge the battery was 2500 minutes.  
 Calculate the energy transferred by the battery.

---



---



---



---



---

Energy transferred = \_\_\_\_\_ J

(3)

The mobile phone includes a sensor to monitor the temperature of the battery.

**Figure 2** shows the circuit symbol for a component used in the sensor.

**Figure 2**

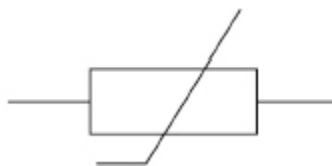

- (e) What component does the circuit symbol shown in **Figure 2** represent?

---

(1)

- (f) The temperature of the component in **Figure 2** increases.  
 The potential difference across the component remains constant.  
 Explain what happens to the current in the component.

---



---



---



---

(2)

**(Total 11 marks)**

5.

A student investigated how the resistance of a wire varies with the length of the wire.

Figure 1 shows the circuit used.

Figure 1

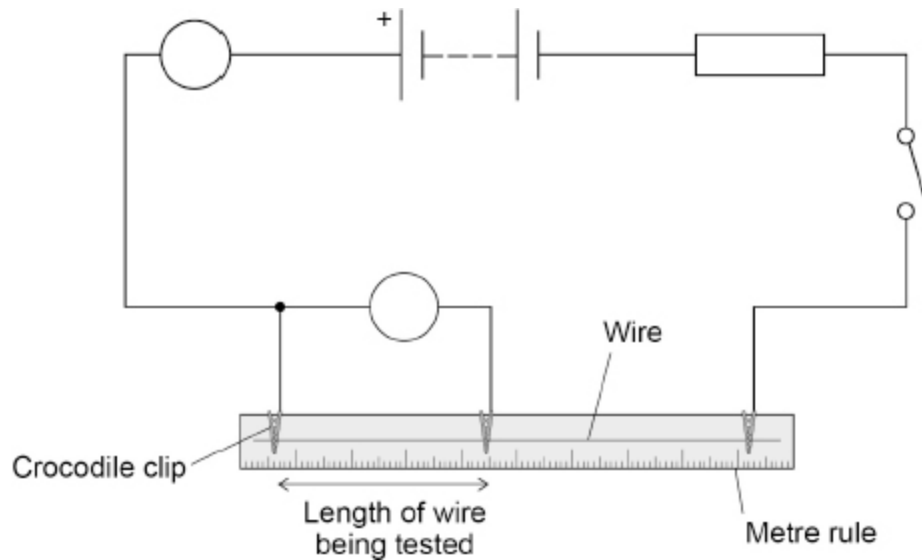

(a) The symbols for the voltmeter and ammeter in Figure 1 are **not** complete.

Complete the symbols for the voltmeter and ammeter in Figure 1.

(1)

(b) Which variable is the independent variable?

Tick (✓) **one** box.

The current in the wire

The length of the wire being tested

The resistance of the wire

The thickness of the wire

(1)

(c) Which variable is the dependent variable?

Tick (✓) **one** box.

The current in the wire

The length of the wire being tested

The resistance of the wire

The thickness of the wire

(1)

(d) The student took repeat readings of potential difference for a 30 cm length of the wire.

The readings were:

0.16 V   0.17 V   0.15 V

Calculate the mean potential difference.

---

---

---

---

Mean potential difference = \_\_\_\_\_ V

(2)

The length of the wire was increased to 60 cm

The current in the wire was 0.50 A

The mean potential difference across the wire was 0.32 V

(e) Calculate the resistance of the 60 cm length of wire.

Use the equation:

$$\text{resistance} = \frac{\text{potential difference}}{\text{current}}$$

---

---

---

---

Resistance = \_\_\_\_\_  $\Omega$

(2)

(f) Calculate the power dissipated in the 60 cm length of wire.

Use the equation:

$$\text{power} = \text{potential difference} \times \text{current}$$

---

---

---

---

Power = \_\_\_\_\_ W

(2)

(g) Calculate the charge flow when there is a current of 0.50 A in the wire for 17 s

Use the equation:

$$\text{charge flow} = \text{current} \times \text{time}$$

---

---

---

---

Charge flow = \_\_\_\_\_ C

(2)

(h) **Figure 2** is a sketch graph of the results.

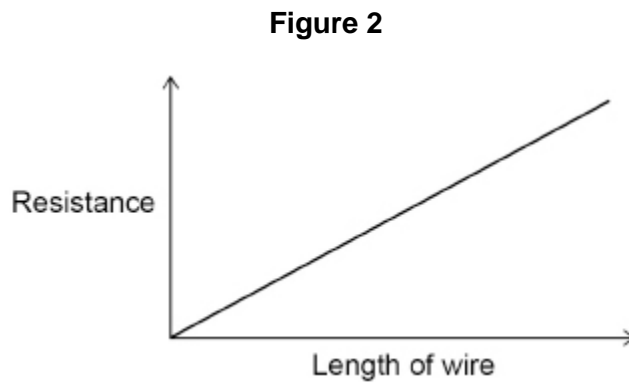

The student repeated the investigation using a thicker wire made from the same metal. For the same length, the thicker wire has a lower resistance.

Draw a line on **Figure 2** to show how the resistance of the thicker wire varies with length.

(1)

(Total 12 marks)

6.

A TENS machine uses an electrical current to relieve pain.

**Figure 1** shows the electrodes of a TENS machine connected across an ankle.

**Figure 1**

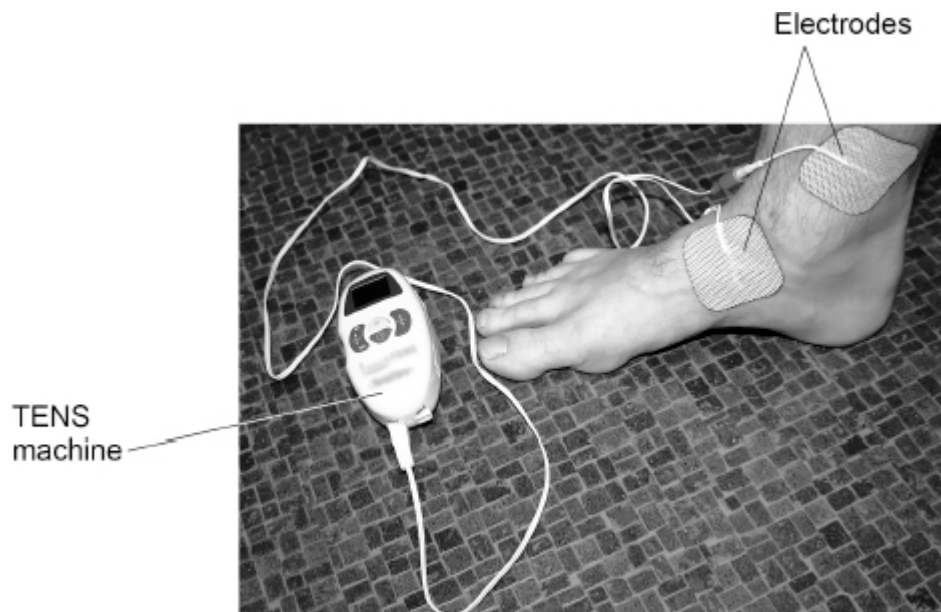

(a) The maximum power of the TENS machine is 240 mW.

The potential difference across the battery in the TENS machine is 2.5 V.

Calculate the maximum current from the battery.

---

---

---

---

---

---

---

---

Maximum current = \_\_\_\_\_ A

**(4)**

- (b) **Figure 2** is a sketch graph showing how the potential difference across the electrodes varies with time.

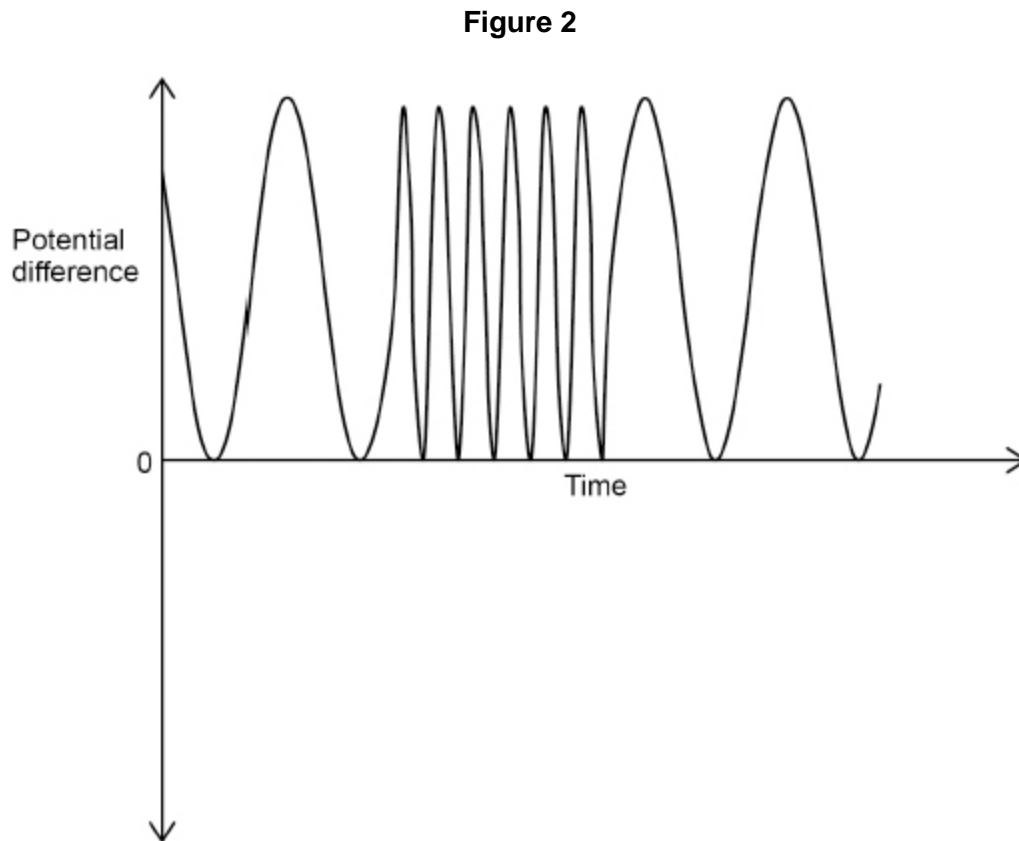

A student concluded that there was an alternating potential difference across the electrodes.

How does **Figure 2** show that the student was **not** correct?

---

---

(1)

**Figure 3** shows a circuit the student built using the battery from the TENS machine.

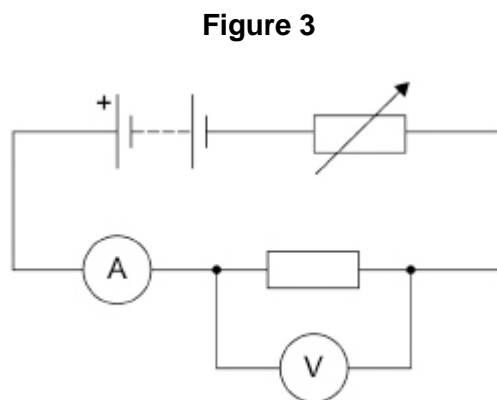

The student recorded how the current in the resistor varied with the potential difference across the resistor.

**Figure 4** shows a sketch graph of the results.

**Figure 4**

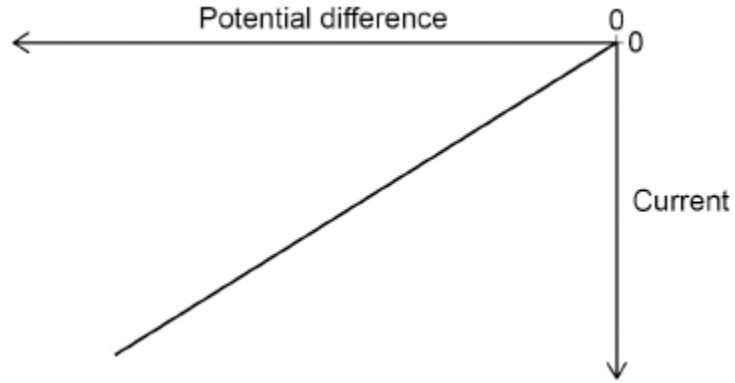

(c) What relationship does **Figure 4** show?

---

---

(1)

- (d) **Figure 5** shows two more circuits that the student built using the battery from the TENS machine.

**Figure 5**

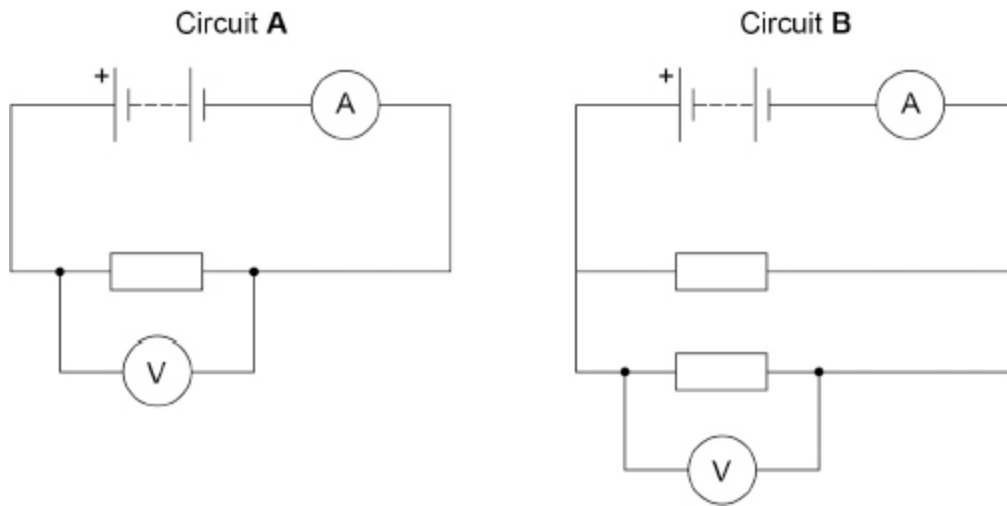

The resistors all have the same resistance.

Compare the readings on the voltmeter and ammeter in circuit **A** and circuit **B**.

Voltmeter \_\_\_\_\_

\_\_\_\_\_

\_\_\_\_\_

Ammeter \_\_\_\_\_

\_\_\_\_\_

\_\_\_\_\_

**(3)**  
**(Total 9 marks)**

## Mark schemes

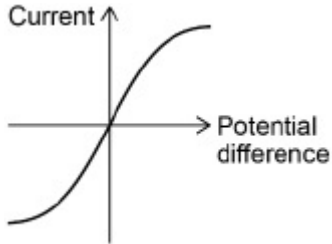
1. (a) battery 1
- (b) variable resistor  
*allow resistor*  
*allow battery / cells*  
*allow correct circuit symbol* 1
- (c) subtract 0.4 volts from each reading 1
- (d) mean =  $\frac{0.54+0.58+0.53}{3}$  1  
*allow mean =  $\frac{1.65}{3}$*   
mean = 0.55 (A) 1
- (e)  $P = 4.8 \times 0.75$  1  
 $P = 3.6$  (W) 1
- (f)  $R = \frac{4.8}{0.75}$  1  
 $R = 6.4$  ( $\Omega$ ) 1
- (g) increase 1  
increase 1
- (h)  1

[12]

2. (a) potential difference is increased  
*allow transformer X is a step up transformer* 1
- (and) current decreases 1
- (so) energy/power losses in the transmission cables decrease  
*allow (so) there is less heating in the transmission cables* 1
- (b)  $11\,000 \times I_s = 400\,000 \times 660$  1
- $$I_s = \frac{400\,000 \times 660}{11\,000}$$
- 1
- $$I_s = 24\,000 \text{ (A)}$$
- 1
- (c) the street lamps are connected in parallel 1
- (d) resistance (of the LDR) increases  
*allow resistance (of the circuit) increases* 1
- (so) the current decreases  
*allow so the LDR has a greater (share of the) potential difference* 1
- (so) the potential difference across R decreases  
*dependent on MP1* 1

(e)  $20 \text{ mA} = 0.020 \text{ A}$

1

$$6.0 = 0.020^2 \times R$$

*allow a correct substitution using an incorrectly / not converted value of current.*

1

$$R = \frac{6.0}{0.020^2}$$

*allow a correct re-arrangement using their incorrectly / not converted value of current.*

1

$$R = 15000 \text{ } (\Omega)$$

*allow an answer consistent with their incorrectly / not converted value of current*

**OR**

$$20 \text{ mA} = 0.020 \text{ A} \text{ (1)}$$

$$V = \frac{6.0}{0.020} = 300 \text{ (1)}$$

$$R = \frac{300}{0.020} \text{ (1)}$$

$$R = 15000 \text{ } (\Omega) \text{ (1)}$$

1

[14]

**3.**



1

(b) the flow of electrical charge

1

(c) all 4 components connected in a series circuit

*allow a cell instead of a battery*

*allow an LED or LDR symbol instead of a lamp*

*ignore the + sign on the battery symbol*

1

(d) decrease the resistance of the variable resistor

1

(e)  $P = 0.75 \times 0.16$

1

$$P = 0.12 \text{ (W)}$$

1

(f) charge flow = current × time

$$Q = It$$

1

(g) 200 mA = 0.2 A

1

$$\text{charge flow} = 0.2 \times 15$$

*allow a correct substitution using an incorrectly/not converted value for current*

1

$$\text{charge flow} = 3.0 \text{ (C)}$$

*allow a correct calculation using an incorrectly/not converted value for current*

1

(h) 1.6

1

(i) 260 mA to 380 mA

1

[12]

4.

(a)  $V = IR$

1

(b)  $3.9 = 0.12 \times R$

1

$$R = \frac{3.9}{0.12}$$

1

$$R = 32.5 \text{ (}\Omega\text{)}$$

*allow  $R = 33 \text{ (}\Omega\text{)}$*

1

(c) energy = power × time

**or**

$$E = Pt$$

1

(d) time = 150 000s

1

$$\text{energy} = 0.46 \times 150\,000$$

*allow a substitution using an incorrectly/not converted value of time*

1

$$\text{energy} = 69\,000 \text{ (J)}$$

*allow a correct calculation using an incorrectly/not converted value of time*

1

(e) thermistor

1

(f) the current will increase

1

(because) the resistance decreases

1

[11]

5.

(a) both symbols correct and in the correct position

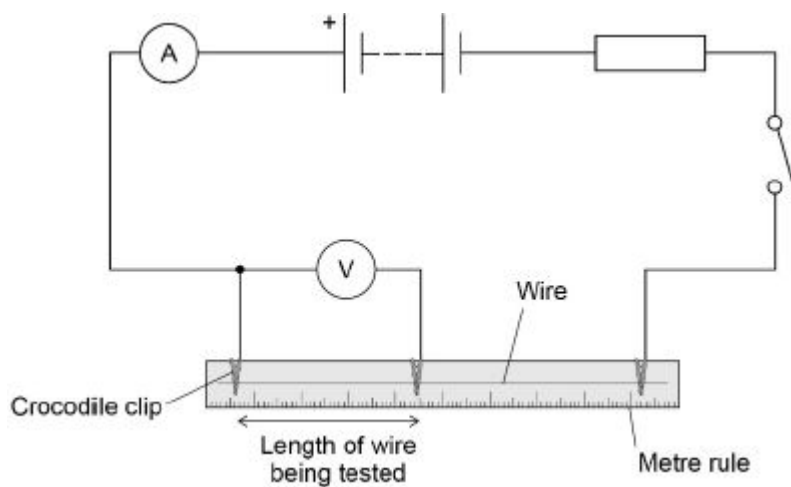

1

(b) the length of the wire being tested

1

(c) the resistance of the wire

1

$$\text{mean p.d.} = \frac{0.16 + 0.17 + 0.15}{3}$$

1

$$\text{mean p.d.} = 0.16 \text{ (V)}$$

1

(e)  $R = 0.32/0.50$

1

$R = 0.64 (\Omega)$

1

(f)  $\text{power} = 0.32 \times 0.50$

1

$\text{power} = 0.16 (\text{W})$

1

(g)  $\text{charge flow} = 0.50 \times 17$

1

$8.5 (\text{C})$

1

(h) a straight line through the origin with a lower gradient

1

[12]

6.

(a)  $240 \text{ mW} = 0.24 \text{ W}$

1

$0.24 = 2.5 \times I$

*allow a correct substitution using an incorrectly/not converted value of power*

1

$I = \frac{0.24}{2.5}$

*allow a correct re-arrangement using an incorrectly/not converted value of power*

1

$I = 0.096 (\text{A})$

*allow a correct calculation using an incorrectly/not converted value of power*

1

(b) because the potential difference is always positive

*allow because potential difference does not change direction*

1

(c) potential difference is (directly) proportional to current

1

(d) voltmeter: the reading is the same in both circuits

1

ammeter: the reading in circuit **B** is twice the reading of circuit **A**

*allow 1 mark for the reading in circuit **B** is bigger than circuit **A***

2

[9]